



Marine Applications

Reliable and fully engineered solutions for propulsion,
deck machinery and fuel optimization

CONTROL TECHNIQUES™
LEROY-SOMER™

Nidec
All for dreams

Providing dynamic, efficient and certified solutions for marine applications

There are many challenges affecting various sectors of the marine industry. These range from:

- High fuel costs, making the need for marine operations to be as efficient as possible
- Heightened environmental regulations driving more sustainable shipping
- Tighter budgets for investing in new vessels, propulsion systems and deck machinery
- Lack of in-house skills and resource to manage upgrades to vessels
- The many difficult operations that have to be carried out at sea, with vessels in very demanding conditions

Control Techniques and Leroy-Somer has long been a key player for providing products, solutions and services for a wide range of applications in the marine industry, covering naval, merchant and pleasure vessels. We provide expertise and leading technology for a large number of partners including vessel owners, ship builders and OEMs/system integrators, with the aim of helping you maximize the performance and efficiency in your marine operations. Our products and systems are designed to naval standards and adhere to specific marine certification regulations.

With vast experience in marine project management, engineering design, commissioning and training, we are a single source supplier of all electrical components and project services for innovative and reliable:

- Energy saving and low-to-zero emission electric and hybrid propulsion systems (including full electric propulsion when entering harbor)
- High performance and safe deck machinery, including anchor and mooring winches, as well as pipe laying equipment including tensioners and various winches (traction, storage and umbilical)
- Efficient onboard grid, pump, compressor and fan systems

Covering both new and retrofit applications, project timescales and costs are minimized, with easy integration with ship wheel house control systems assured with our multiple Ethernet and fieldbus communications protocols.

Nidec marine systems are flexible and customized to the exact requirements of your vessel, ensuring maximum performance and functionality from our core drive, motor and alternator technology. Reliability is guaranteed with innovative full-load testing on propulsion systems prior to installation. Products can be adapted to specific marine and submarine requirements such as high shock resistance and EMC protection to military levels, while noise and vibration are minimized, ensuring occupant and ride comfort.



Global solutions and services

With many marine applications in existence across a wide range of vessels, our global organisation provides:

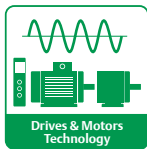

Cutting edge drives, motors and alternator technology – Our market leading products provide the performance and functionality needed to produce effective control solutions for propulsion and wide variety of deck machinery applications



Scalable Automation Solutions – from small retrofit projects to full electrical marine solutions, backed by our highly experienced and qualified global application teams

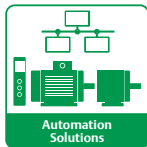

Customized local services – all elements of system requirements are supported through our worldwide Automation Center network, including design, installation, commissioning, optimization, after sales support and training

History of marine innovation

Control Techniques and Leroy-Somer have a rich history of innovation in the marine sector, with a huge list of references upon request. Key developments include:

- 1965 Concealment - Discreet shock resistant motors for submarines.
- 1975 Compactness - High mass power motors for torpedo propulsion (25 kg ≥ 100 kW).
- 1980 Detection - Shock resistant, non-magnetic motors for sensitive auxiliaries.
- 1990 Security - Alternators for emergency energy production.
- 1995 Energy management - Discreet asynchronous motors with frequency converters.
- 2003 Flexibility - Navalization and military qualification of frequency converters.
- 2014 Electrical innovation – Key partner in developing the world's first fully electric super yacht.
- 2016 New liquid cooled motors - Highly compact and powerful, with low audible noise; ideal for all vessels.

Most recently we have been heavily involved in hybrid and electric developments. We also collaborate closely with partners, integrating with their marine control and monitoring systems. Control Techniques and Leroy-Somer continue to strive forward in developing innovative marine solutions, to meet and exceed the wide and varied needs of all sectors within the marine industry.

Global facilities and resources

Nidec provides global project management, with engineering resources dedicated to solutions to Marine standards and is present in all countries involved in marine-related industries.

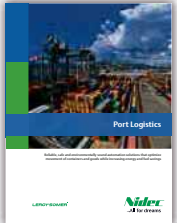

Read about Nidec's reliable, safe and environmentally sound automation solutions for Port Logistics that optimize movement of containers and goods while increasing energy and fuel savings.

An enhanced global presence that benefits all our customers

Through our integrated Drives & Motors and Electrical Power Generation organization, we have an extensive global presence that provides comprehensive local support & services. This includes:

 10,000 employees



40+ Automation Centers

Providing excellent customer support for any product, automation solutions or service requirements



32 Manufacturing sites

Producing a comprehensive range of high quality products, optimized for industry-specific customer requirements



8 Engineering and Design facilities

Develops market leading products and feature-sets using the latest design technology



3 Regional despatch hubs

For quick delivery of product

Our extensive sales and service networks in Europe, Asia Pacific and the Americas are backed-up by hundreds of carefully selected distributors and service partners, often in remote locations, all over the world.



Note that many countries have more than one of the facilities represented by the icons.

Services are optimized on a country-by-country basis, so please contact your local sales contact for full details of our local offering.

Typical solutions for Marine applications



Maximum power ratings

Alternators: up to 20 MW (26,800 hp)
Drives & Motors: up to 2.8 MW (4,200 hp)

Shaft, stand-by and emergency alternators

Alternators



Main electric/hybrid propulsion

Alternators
Drives
Motors



Auxiliary propulsion

Motors
Drives



Auxiliary supplies

Alternators



Energy & fuel saving RISGA system

Alternators
Drives



Water cooling & ventilation system

Drives



We are able to provide a wide range of products and solutions for numerous marine applications. These include adapted products to military standards, such as:

- Extended shock resistance (up to 15 G for drives & 168 G for motors)
- Low noise levels
- EMC protection
- Compact and modular products with high power density and liquid cooled features

To operate in the most severe of marine conditions, our product reliability is improved through:

- Elimination of vibration
- Qualification
- Life cycle improvement/management
- Crew training



Refrigeration compressors

Motors
Drives



Oil separators

Motors



Deck machinery applications

Includes tensioners, cranes, pipe laying equipment anchor & mooring winches, ...

Brake motors
Gears
Drives



Pod steering

Motors



Pumps, fans & heat exchangers, including sewage treatment

Motors
Gears
Drives



Solutions for marine propulsion and deck machinery applications

Global expertize perfectly executed at local level

We have a group within our organization that is dedicated to designing, managing and implementing global solutions projects. This allows us to leverage and mobilize our worldwide marine expertize and automation knowledge across every project. Dedicated local teams based at our Automation Centers ensure each stage is perfectly executed, providing:

- Specific marine application-focused solutions optimized for reliable and maximum operation
- Highly skilled propulsion system and winch control designs to create innovative and fuel saving solutions
- Maintenance and trouble-free operation
- Flexibility for future vessel requirements and developments
- Compliance of full system to required marine certification

Scalable automation solutions

Projects can vary from small drive, motor and alternator retrofit projects, to fully designed, engineered and customized propulsion (hybrid and electronic) or deck machinery control systems for a wide variety of vessels. We can scale a solution to work with your budget. Many of our customers are looking to improve efficiencies using operational expenses (OPEX) rather than large capital expenditure (CAPEX). Refurbishment, or even partial refurbishment, projects can target the areas of largest impact, guaranteeing maximum operational and financial benefits. You can be assured that we are able to take on completely new installations or modernize any existing installed systems.

On-time project delivery, within budget

The local team provides a single point of contact for our customers, building a long term partnership while ensuring the correct resources and expertise are always available. Dedicated team roles safeguard against resource constraints, with continuous monitoring and risk assessments to ensure prompt and effective action in response to evolving project requirements. Our regional knowledge allows us to collaborate with local supply chains and easily adhere to the relevant country's marine and electrical standards. This ensures we can guarantee project delivery is on time and within budget.





Adding value to your business

We want our partnership with you to develop over many years, continuously adding value to your business. Comprehensive maintenance and servicing is available to ensure trouble-free operation, along with the following offerings:

- Management of future equipment and machinery requirements or retrofit projects
- Upgrades to hardware/software as technologies advance
- Onboard software development for fine-tuning performance
- Provision of add-on functionality as your needs expand
- Support for business and staff training needs when required

Comprehensive electrical solutions

For new electric control systems or retrofit projects, we can provide fully engineered solutions. By working with a single supplier, we act as a one-stop shop for all your system and support requirements including specification, design, build and commissioning.

The project services we offer includes:

- Project management from experienced marine application leaders
- Functional design specifications
- Detailed engineering design that incorporates:
 - drives, motors, alternators and integrated control & monitoring systems that meet and exceed customer's internal quality requirements
 - integrated state-of-the-art safety controls
- Software application development, including:
 - power management systems
 - battery management systems
- Procurement of all system components
 - assembly of electrical control system, including manufacturing of cubicles and control panels
- Commissioning, start-up and optimization
- Certified compliance to marine classification societies
- Detailed project documentation
- Training



Flexible propulsion systems to meet your exact vessel needs

We have a deep experience in designing and implementing customized electric, hybrid and auxiliary propulsion systems, which are specific to your vessel requirements. Our innovative and reliable solutions are highly efficient, optimizing energy and fuel consumption to the exact power requirements of each operation. Modular drive systems provide compact design with built-in redundancy and low emission propulsion. The use of stored battery or harbor grid power through a Variable Frequency Shore Connection can result in zero NOx and CO2 emissions, which is now a requirement when maneuvering in many ports. Also, we provide innovative and flexible electrical motor ranges for propulsion with reduced audible noise, enhancing passenger ride comfort. Furthermore we develop intuitive Power Management Systems (PMS) and Integrated Alarm Systems (IAS) for safety and security.

For many years we have provided drives and control, motors and alternators for OEMs and system integrators for naval, merchant and pleasure vessels, proving the reliability, efficiency and performance of our technology.

We now design, engineer and install full propulsion solutions in many different configurations which are tested under load conditions before installation, easily integrating with vessel control systems, while providing full marine system certification.

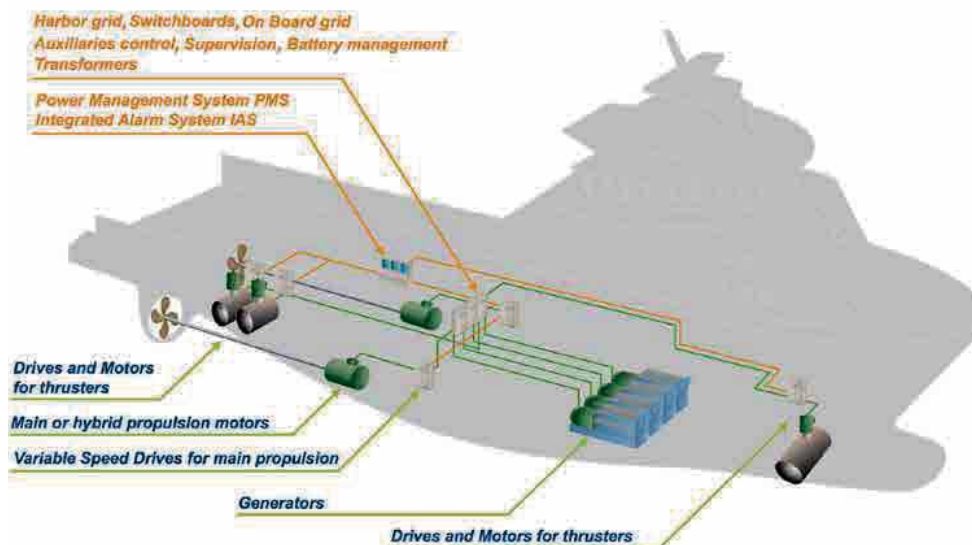

Hybrid design CODLOD/CODLAD

Different propulsion systems

- Classic or Direct drive hybrid, including CODLAD (Combined Diesel/Electric and Diesel Engine) & CODLOD (Combined Diesel/Electric or Diesel Engine) configurations
- Vessel sailing at slow speed using electric propulsion (CODLOD)
- PTI Booster mode (CODLAD)
- Tested under load conditions before installation
- Easy integration with vessel control systems

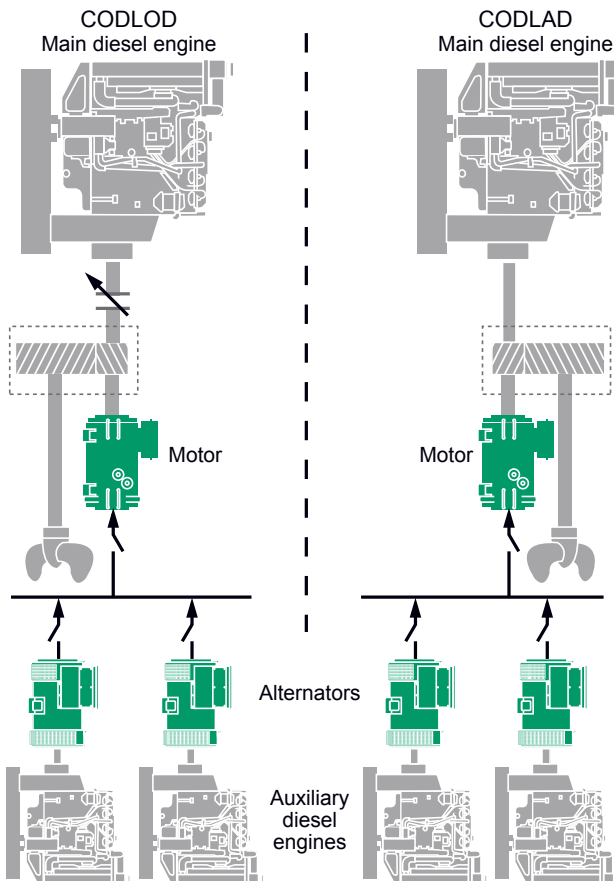

Diesel/Electric design

- Compact engine room design & enhanced installation flexibility
- Scalable power solution provides improved energy efficiency
- Complete electrical system including:
 - automation
 - power management system
- Flexibility to accommodate 50 or 60 Hz port supply
- Air and water cooled options
- Direct drive solutions (without gears)

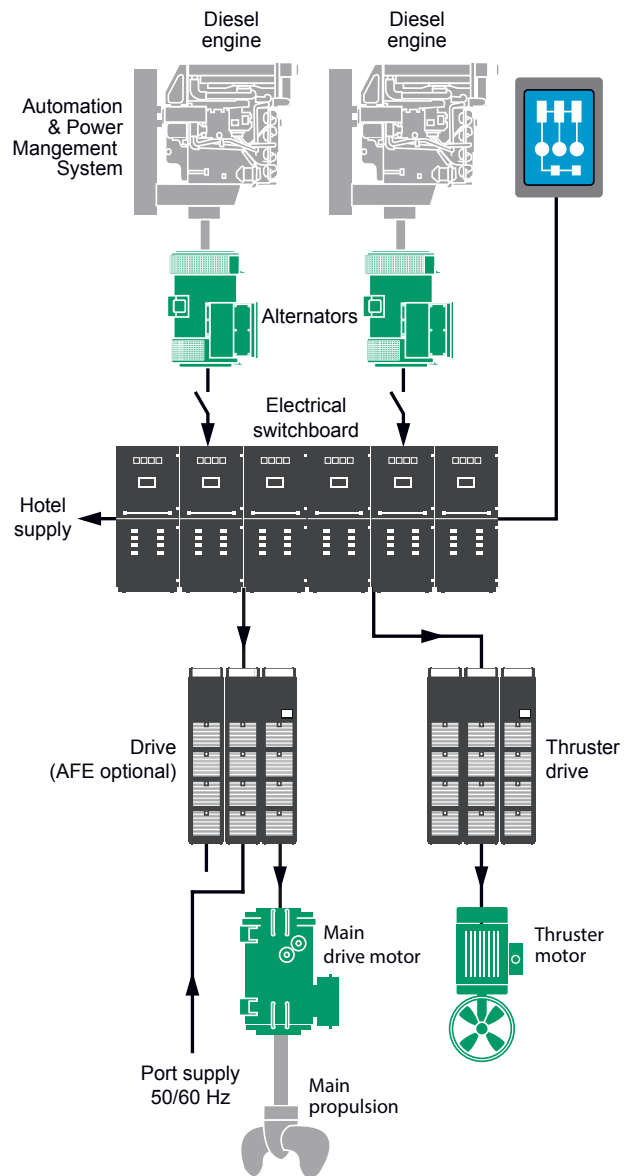

PTO/PTI Hybrid Modes

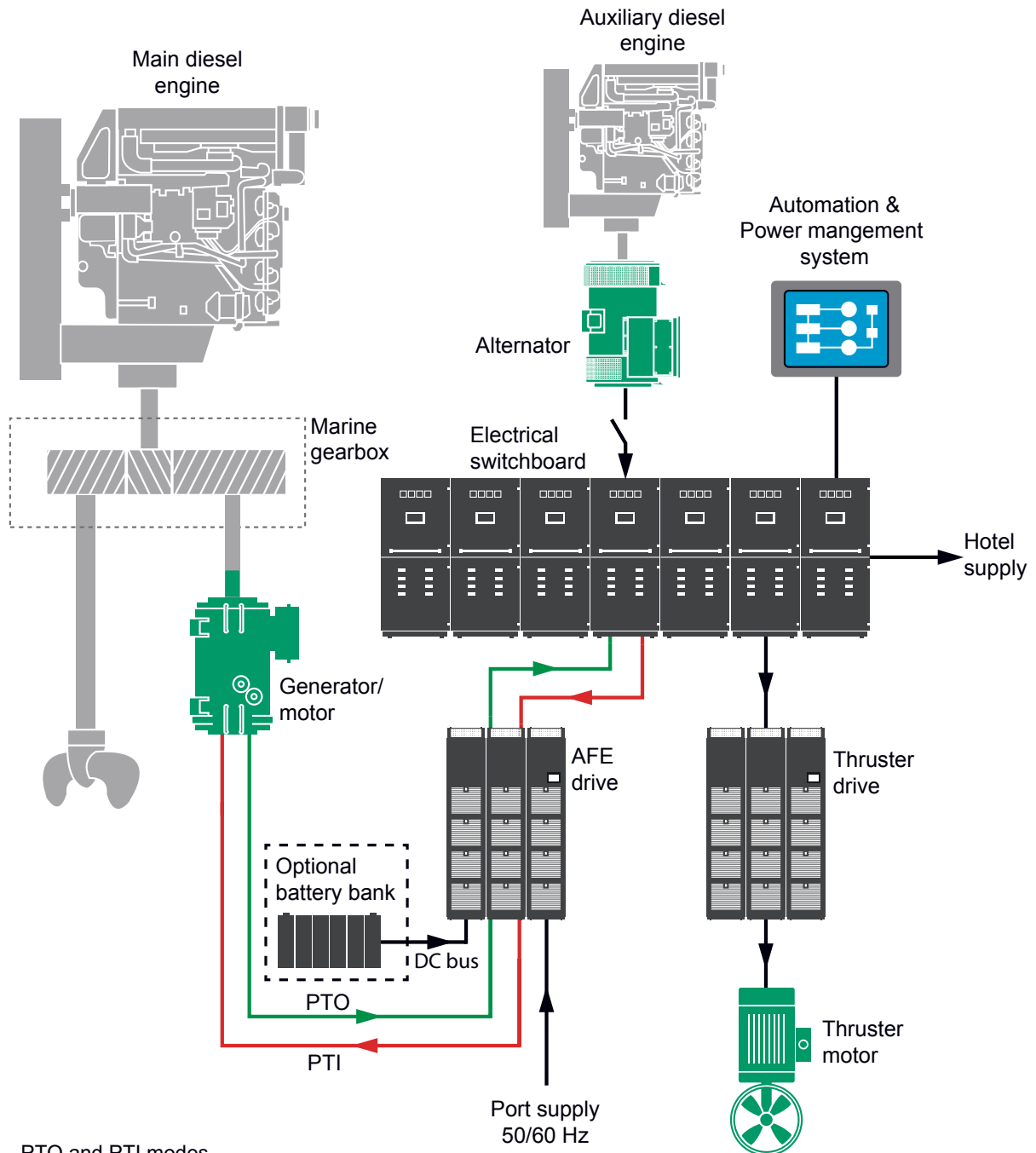

- PTO and PTI modes
- Take me home safely mode (if main diesel engine fails)
- Boost mode for additional power requirements
- Optional batteries and battery management system
- Reduced emission running capability
- Complete electrical system including automation and power management system
- Flexibility to accommodate 50 or 60 Hz port supply
- Air and water cooled options available
- Direct drive solutions (without gears)

All Electric Ship (AES)

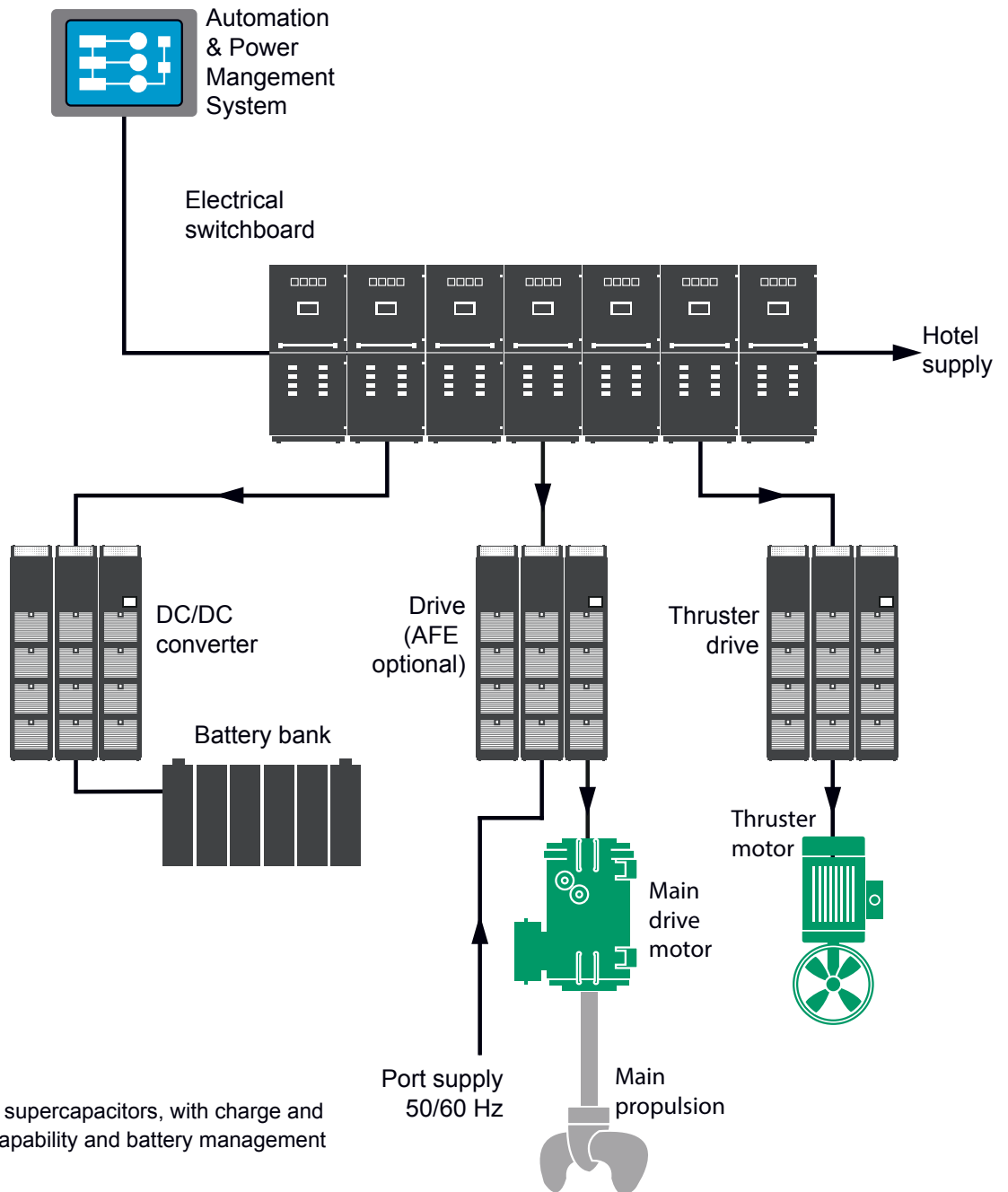

- Batteries or supercapacitors, with charge and discharge capability and battery management system
- Low to zero emission running capability
- Innovative technology capability using permanent magnet motors for reduced consumption and footprint/weight
- Complete electrical system including automation and power management system
- Flexibility to accommodate 50 or 60 Hz port supply
- Air and water cooled options available

Smart, reliable onboard power generation

Solutions for powerful onboard grids

Onboard a vessel, systems and processes need to be autonomous, reliable, and efficient. While needing to operate daily with good business efficiency they also need to be ready to withstand unexpected and extreme conditions.

Power is needed everywhere

Electrical supply has proven to be the most reliable, versatile and flexible way of powering the most critical processes onboard any vessel, such as heating, pumping, cooling and moving. Ships have grown into complex, autonomous systems where the power grid has become a key opportunity for daily money savings.

Integrated digital solutions

The answer? High performance alternators combined with optimized digital regulation, leading to low energy consumption and improved system efficiency.

This also allows for a direct integration into the system control and monitoring.

Our offering

Our teams have the experience and know-how to build smart onboard power systems for all prime, standby and critical applications. With several years of experience and a long track record of successful projects, we will deliver exactly what is needed: we don't over-specify, and we will never compromise on safety.

Our Marine-grade products are built for the high seas:

- Certification: we meet and exceed the highest marine requirements
- Environment: salt, temperature and moisture protected
- Fitting: compact, easy to install designs
- Operations: reduced maintenance, vibration resistance

High reliability, availability and flexibility mean that your power supply will always provide what is needed, when it is needed. This means cheaper daily operations, and better answers to critical situations.



Energy reductions in ventilation and water cooling systems

Water cooling and ventilation systems in engine rooms for all vessels are manufactured to tropical specification (32 °C), with the supply diesel engine running constantly at 100 % load. With the exception of a few specific areas, water and ambient temperature is generally cooler globally. As such, cooling systems are working harder than required, and present a good opportunity for saving energy and fuel costs. Accurate monitoring and measuring takes into account vessel location, ambient room and sea water temperature, with precise real-time regulation of the engine to these needs, through accurate Nidec control systems, typically:

- A reduction of 10 Hz in ventilator frequency sees the energy consumption decrease by about 44%
- When the number of ventilator revolutions is decreased by half, the absorbed power decreases by about 73%
- Nominal speeds of ventilators reduce by around 60 %, with decreased sound production of 8 dB at a distance of 2 m

Benefits include:

- Only minimal data provided by the Captain on standard template allows us to provide accurate estimation of energy savings
- Installation of our solution can be handled by the crew while underway, and commissioned by Nidec on arrival in port
- Failsafe solution complete with bypass to ensure constant operation
- Temperature sensor is flange mounted on a non-essential supply and so does not require certification
- Quick ROI, with savings of around \$80,000 per vessel over a year
- Reduced environmental impact (emissions and noise)
- Maximize operational performance of the ship

Energy and fuel saving with RISGA

Nidec's proven RISGA fuel saving solution, is low cost and compact and intelligently manages the diesel engine's speed to meet actual system requirements of electrical auxiliaries. By minimizing energy and fuel consumption, this helps reduce the overall operational cost of the vessel. Also it decreases component wear and extends the operational life of the diesel engine and electrical auxiliaries, with payback usually in 1 to 2 years.

Nidec

Providing expert control for deck machinery applications

With many partnerships with winch and hoist manufacturers, our products and control systems are ideally suited to marine applications, and are commonly used in the following:

- Dynamic anchoring, mooring and winch applications
- Onboard crane and hoist applications
- Active heave compensation
 - safe load & offshore hoist operations while transporting to fixed points
 - low inertia motor technology to increase productivity

Nidec can provide the expertise, technology and services to deliver reliable, safe and high performance control systems required to operate deck machinery in harsh marine conditions. Every system is individually designed to the exact requirements of each vessel and piece of machinery, and can be certified to marine standards.

Optimized and efficient control of deck machinery

Our control systems incorporate industry-leading software into the drive and motor solution, monitoring the physical and operating conditions of winch and hoist machinery on a real-time basis. It can be used to optimize the equipment's movements and trajectories, relieving the operator of delicate and repetitive tasks, while improving position location. Also highly accurate tension control means anchoring and mooring lines can react instantly to wind, current, wave and tidal speed changes.

Highly accurate motion control for marine applications

Nidec can provide highly accurate motion and tension control solutions for many marine operations including:

- Pipe laying equipment - control systems for tensioners and traction, storage and umbilical winches for operation in challenging conditions
- Underway replenishment at sea – where two ships or more connect using lines for transporting cargo, supplies and fuel whilst traveling at speed
- Naval weapons systems – to compensate for wave displacement when aiming at targets

Our drive systems and customized software provide real-time monitoring of sea, load and climatic conditions and positional control allows vessels to compensate quickly in order to achieve highly intricate operations. Efficient movements and careful load management mean less power and fuel are required, reducing the cost of operations, extending service lifetime of machinery and increasing overall safety and reliability.



Easy-to-use and innovative system interfacing

Our latest generation products, HMIs and software tools, draw from extensive user research and human centered design principles. System integration, commissioning, optimization and monitoring are now even more intuitive, due to our use of:

- Industry standard communication protocols and open programming environments for seamless integration with vessel operation systems and other deck machinery
- Intuitive graphical software tools enhance and simplify drive system commissioning and maintenance.
- Matched drive and motor mapping for automatic optimization
- Use of popular SD cards in drives for quick and easy parameter and program storage
- Remote control monitoring, enhancing deck machinery up-time and performance

Nidec customized services and support to ensure optimized operation for the life time of your system

An extensive global service team offers support to Nidec customers whenever and wherever it is needed. The Nidec service team consists of a large global network, often allowing customers to receive locally-based assistance. Where appropriate, we are able to use remote diagnostic technology to monitor data, status, fault and performance with the goal to help the vessel maintenance team and to minimize equipment downtime. Nidec engineers are highly trained in the service and maintenance of Nidec Automation Solutions, with particular emphasis on safety. We ensure responsible and dedicated support.

Nidec offers you different levels of service to suit your needs

These comprise of:

- Remote technical service with in-house skills for services and training
- On-site technical service tailored to customer needs
- Periodic inspections
- Supervision of maintenance
- Scheduled and preventive maintenance
- Express Availability service for spare parts
- Repair services
- Standard training programs
- On-site training for operators and maintenance & safety training provided to minimize absence periods of valuable people

At the highest level, we can assure optimum operative availability of automation equipment through planned proactive maintenance. This is supported by our service strategy and the services of experienced engineers to monitor and inspect your equipment.



CONTROL TECHNIQUES™

LEROY-SOMER™

www.nidecautomation.com



www.blrtera.ee

Contact us!

BLRT ERA AS
+372 610 2307
era@blrt.ee

BLRT ERA AS Lithuania Branch
+370 65 561 697
era@wsy.lt

Nidec
All for dreams

Control Techniques Limited. Registered Office: The Gro, Newtown, Powys SY16 3BE. Registered in England and Wales. Company Reg. No. 01236886.

Moteurs Leroy-Somer SAS. Headquarters: Bd Marcellin Leroy, CS 10015, 16915 Angoulême Cedex 9, France. Share Capital: 65 800 512 €, RCS Angoulême 338 567 258.

0701-0063-03
5303 en - 2017.05 / e